

Assembly Instruction

3-TIER WIRE SHELVING

1. Please read the assembly instructions carefully before assembling and check all the parts.
2. Please check the parts quantity
3. Do not touch the cut surface of tube



Parts Identification



A

4PCS

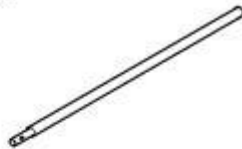

B

4PCS

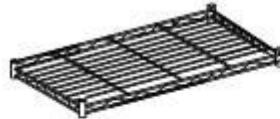

C

3PCS



D

24PCS

Step 1

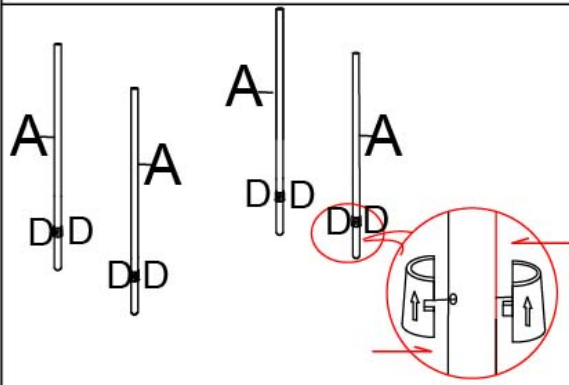

Put part (D) into the hole of part (A), please noted the gap of part (D) must be up.

Step 2

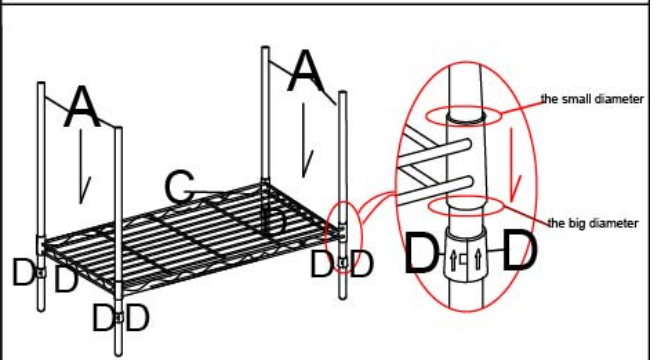

Put metal net (C) into tube (A), and arrive to the position of part (D), and note the diameter size of metal net (C).

Step 3

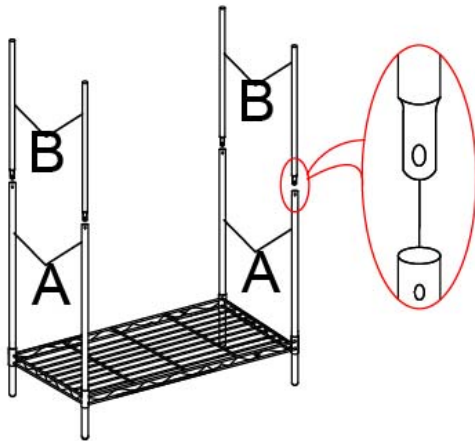

Insert tube (B) into tube (A), aim at the hole.

Step 4

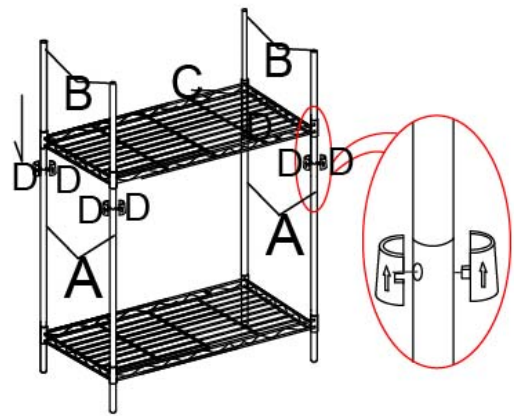

Fasten part (D) into the hole of part (B), then put the metal net (C) into tube (B).

Step 5

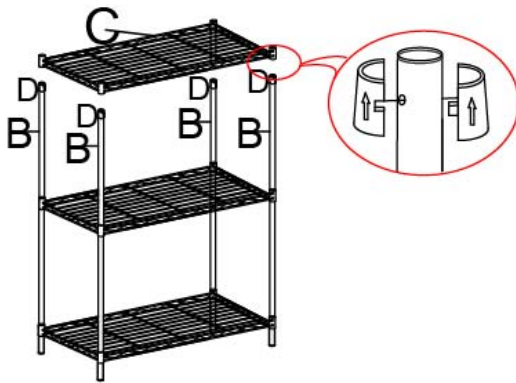

Fasten part (D) into the top hole of tube (B), then put metal net (C) into tube (B).

Step 6

